

**EX21 Configuration Chart**

Optical System	Infinity color corrected optical system
View Head	30° inclined, gemel binocular head, interpupillary distance 47mm-75mm 30° inclined, gemel trinocular head, interpupillary distance 47mm-75mm, light splitting ratio R:T=8:2
Eyepiece	high eye point wide field plan eyepiece PL 10X/18mm, with adjustable diopter
	high eye point wide field plan eyepiece PL 10X/20mm, with adjustable diopter
Objective	Infinity plan achromatic objective (4X、10X、20X、40X、60X、100X)
	Infinity plan positive phase contrast objective (10X、20X、40X、100X)
Nosepiece	reversed quadruple / quintuple nosepiece
Focusing Mechanism	low position coaxial focusing mechanism, coarse range: 25mm, fine precision: 0.002mm, with tension adjustment and upper limit
Stage	150mm X 140mm double-layer composite mechanical moving stage, double slice clamps, moving range: 76mm x 50mm; accuracy: 0.1mm (triangular guide rail)
	150mm X 162mm double-layer composite mechanical moving stage, double slice clamps, moving range: 76mm x 50mm; accuracy: 0.1mm (X-axis single rail driving) without rack protruding structure, stage surface with wear resistant and corrosion resistant treatment
Transmission Illumination System	N.A.1.25 compound eye illumination condenser group (with plug-in phase contrast and dark field accessories' interface), condenser preset center, optional lifting function, adaptive 100V-240V switching power supply, single high brightness 3W LED (cold/warm color optional, cold color temperature 4750K-5500K, warm color temperature 2850K-3250K) (preset center), light intensity can be continuously adjusted
Camera Adapter	0.35X/0.5X/0.65X/1X C-mount adapter, focusing adjustable
Others	polarizers, analyzers, colour filters, filters, phase contrast panels, dark field panels

**EX21 Dimension Chart: mm**

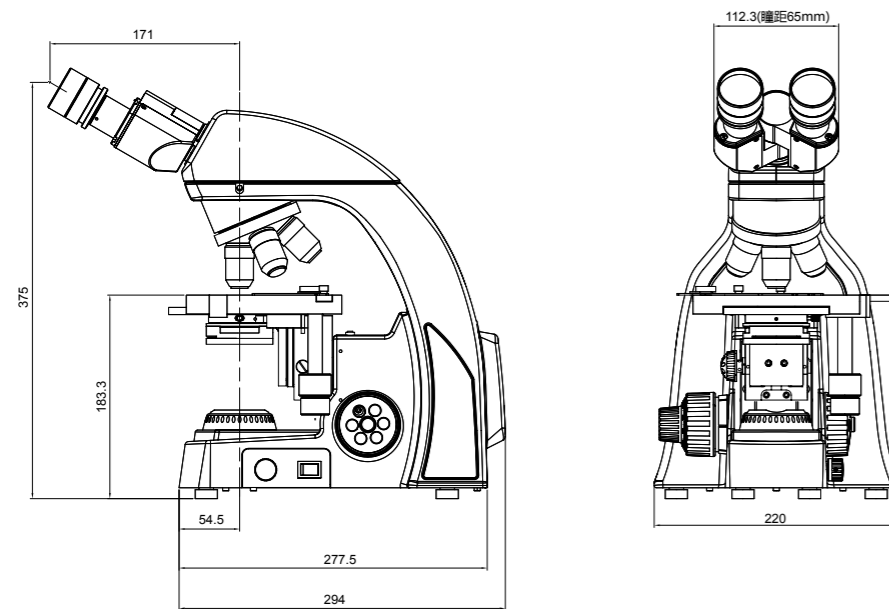

NINGBO SUNNY INSTRUMENTS CO.,LTD.

www.sunnyoptical.com  
C1501B-1903  
No additional notice for changes on the specification or appearance

ADD: No.66-68 Shunyu Road, Yuyao, Zhejiang.  
TEL: 0086-574-62553380  
FAX: 0086-574-62530066  
ZIP: 315400  
E-mail: sales@sunnyoptical.com



# EX21 | Compound Eye Illumination System, Lighting Ideal Light Path

SOPTOP EX21 is a high quality biological microscope, which is an ideal choice for basic research and teaching experiments.

With infinity color correction optical system and excellent compound eye illumination system, EX21 can get uniform illumination, clear and bright images at any magnification. User-friendly design, simple and convenient operation, even students can easily master.

Similarly, same as all SOPTOP microscopes, EX21 maintains excellent reliability and durability, and is suitable for high-intensity use in the education market.

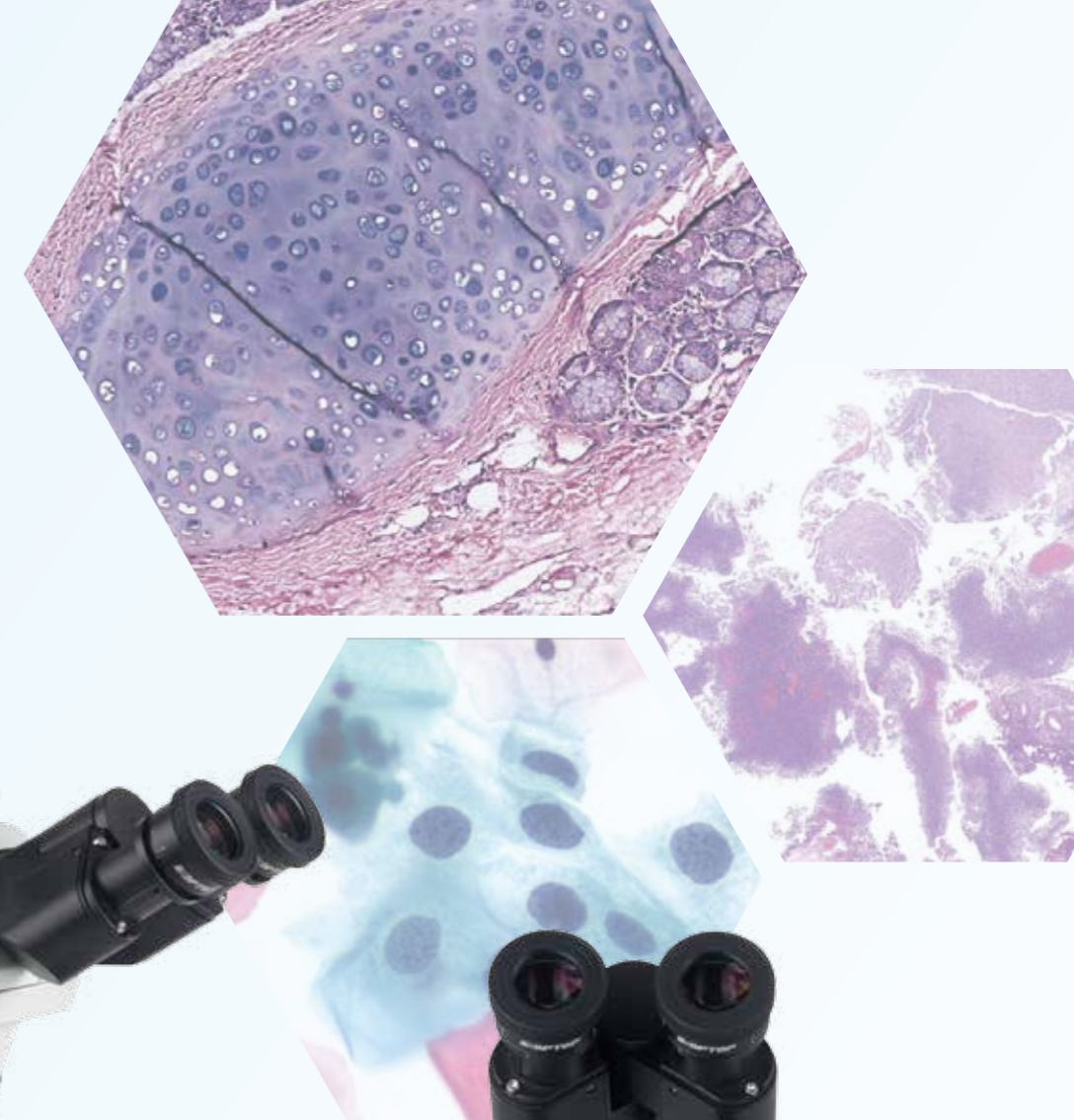

## Large interpupillary distance adjustment range brings professional observation experience

30° inclined, gemel viewing head, interpupillary distance 47mm–75mm, which can meet the needs of more people.

Professional high eye point, wide field plan eyepiece can effectively correct the distortion and color ring of the field of view edge. Strong structural design can effectively prevent students from disassembling eyepieces and avoid the phenomenon of lens refitting, damage and stain after students use them.



PLAN Infinity Plan Achromatic Objective Series



PLAN-PH2 Infinity Plan Positive Phase Contrast Objective Series

Model	Magnification	N.A. (mm)	WD (mm)	Coverslip Thickness (mm)	Immersion Liquid	Spring
PLAN Infinity Plan Achromatic Objective Series	4X	0.10	11.9	–	–	–
	10X	0.25	12.1	–	–	–
	20X	0.40	1.56	0.17	–	–
	40X	0.65	0.36	0.17	–	Yes
	60X	0.85	0.3	0.17	–	Yes
PLAN-PH2 Infinity Plan Positive Phase Contrast Objective Series	10X	0.25	12.1	–	–	–
	20X	0.40	1.56	0.17	–	–
	40X	0.65	0.36	0.17	–	Yes
	100X	1.25	0.21	0.17	Oil	Yes

## User-friendly Design to Increase Comfort and Safety

In order to provide you a better operating experience, the EX21 body adopts a smooth curve design, eliminating all sharp edges; the frame is hollowed out, increasing the position of handles for easy handling; the "bell" appearance design is stable, compact and beautiful, and the charging adapter is built-in, saving laboratory space.



## Compound Eye Illumination System, Lighting Ideal Light Path

EX21 innovatively adopts the compound eye illumination system to improve the contrast rate and effectively improve the illumination uniformity of the specimen surface. The brightness of the entire field of view is uniform. Even at the edge of the field of view, uniform and bright background brightness can be achieved under any magnification. Soft light, not harsh, not only the imaging effect is more ideal, but also can reduce the sense of fatigue, improve the observation experience.

LED light source is environment-friendly. Compared with halogen lamps, it consumes less energy and provides about 100,000 hours of sustainable lighting.

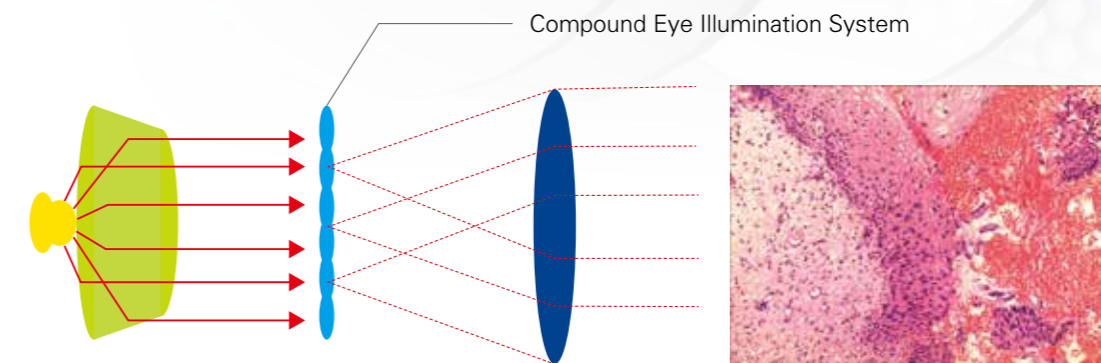

## Continuous Adjustable Light Intensity, Easy to Operate

The side of the frame is equipped with a dimming knob, which can easily adjust the illumination brightness by gently rotating.

Continuous adjustable light intensity can effectively overcome the brightness jump phenomenon in traditional microscopes, and avoid the dizziness caused by instantaneous strong light.

## Power Wire Easy to Store

EX21 has a storage box on the back, which makes full use of the built-in space of the body and can be used to store the power cord conveniently. SOPTOP is designed to make your desktop look clean and tidy.



Various optional accessories, easy to achieve observation methods of bright field, phase contrast, simple polarization, dark field and others.

### Bright Field Observation

The compound eye illumination system is equipped with professional plan achromatic objectives and has bright imaging. It can be used to observe cell structures and analyze plant slices.

### Phase Contrast Observation

It is applicable to observe the specimens with high transparency, such as cells, bacteria and other small, transparent objects in biological specimens.

### Simple Polarization Observation

It can judge substances with birefringence characteristic such as animals, plant cells and humoral crystals.

### Dark Field Observation

There is no need to replace the special dark field condenser, as long as the dark field accessories are inserted into the condenser and the diaphragm is switched, the dark field lighting can be realized.

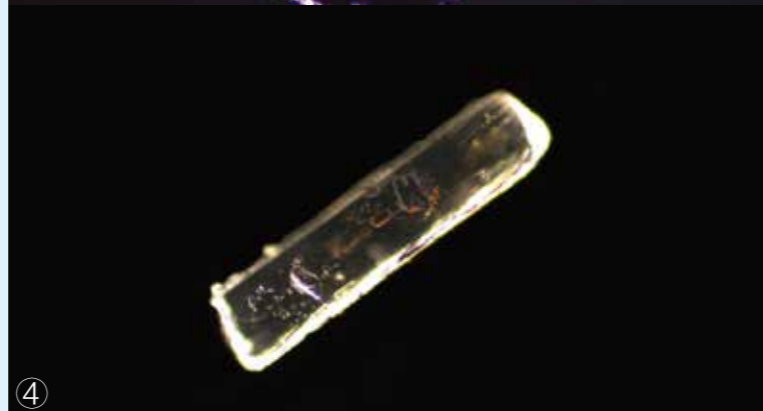
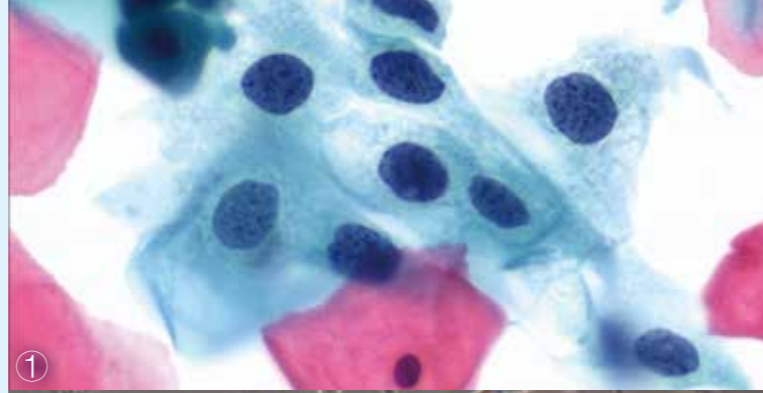

- ① Endometrial Carcinoma 40X Bright Field
- ② Adherent Cells 10X Phase Contrast
- ③ Pine Needles 10X Polarization
- ④ Sodium Glutamate Crystal 10X Dark Field



### EX21 System Configuration Chart

